

RP126Si



An adjustable, automatic door bottom seal that is spring loaded to lift clear of the floor when the door is opened. Acoustically designed, featuring extruded silicon gaskets for medium temperature smoke applications. RP126Si is operated automatically by pressure on the door jamb or stop by its adjustable strike. It is self levelling.

Location: Face mounted or semi-morticed into the bottom of single and double solid core butt hinged doors. Minimum door thickness of 35mm recommended for semi morticed installations with plain meeting stiles. Minimum door thickness of 40mm recommended for semi-morticed installation with rebated meeting stiles. RP126Si can also be face mounted to the bottom of metal doors.

Min/Max Gap: 3mm to 14mm.

Finish: Satin clear (silver) anodised aluminium (15µm) or paint at extra cost.

Fixing: Screw fix. Colour matched escutcheon plates and zinc plated, cross recess head S.T. screws supplied.

Seal: RP3126Si. Black silicon rubber (SE).

Sizes: 1500mm, 1220mm, 1070mm, 920mm, 820mm, 600mm to 305mm (min). Seals cut back to exact size.

Approvals

UL R37913.

Certifire CF 5710.

Acoustic AUS/NZ: NCC Spec. F5.5.
UK/EU: Approved Document E. Rated to BS EN ISO 717-1.

Fire AUS/NZ: NCC Spec. C3.4.
AS1530.4 & AS/NZS 1905.1. NZ BC Compliance Doc. C/AS1 6.19.2 & App. C6.1.1.

UK/EU: Approved Document B.
BS EN 1634-1.

FRL & FRR-/240/30.
Gasket flammability index 1 when tested to AS1530.2.

Smoke NCC Spec. C3.4. AS1530.7 & BS EN 1634-3. Meets smoke leakage rates specified in AS6905 & EN 13501-2 "Sa", "Sm".

Energy NCC Pt. 3.12.3.3 & J3.4.

Durability Tested to over 1,000,000 operating cycles without failure.

Insects/Vermin AS4674, 2.1.5(iv), 2.1.7.

Patented, Registered Design.

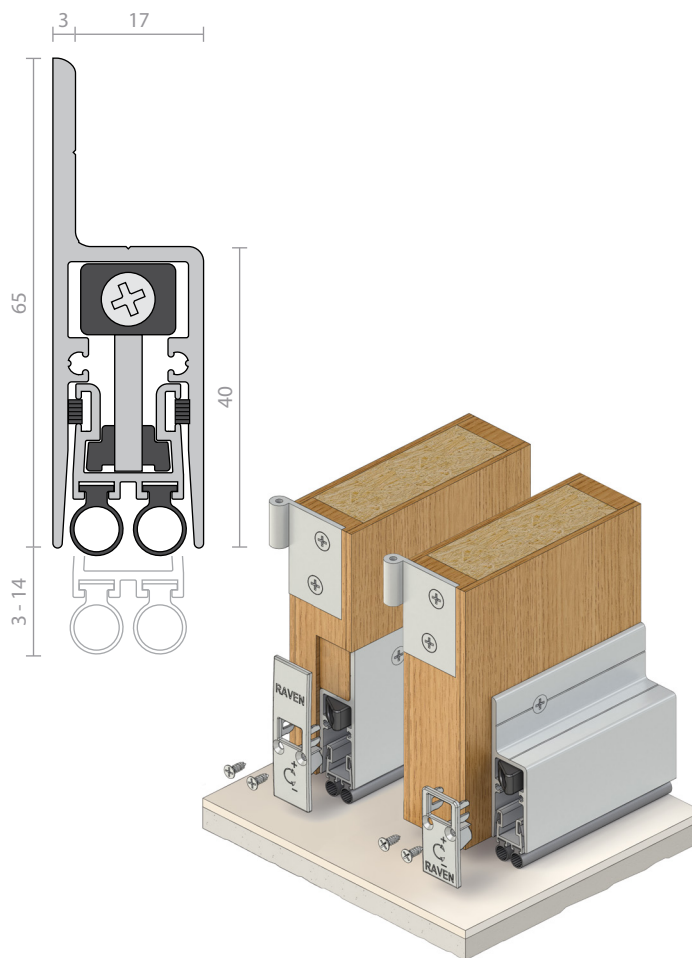

RP127Si



An adjustable, automatic door bottom seal that is spring loaded to lift clear of the floor when the door is opened. Acoustically designed, featuring extruded silicon gaskets for medium temperature smoke applications. It is operated automatically by pressure on the door jamb by its adjustable strike. It is self levelling.

Location: Fully morticed into the bottom of single and double solid core butt hinged doors (minimum door thickness of 40mm). For double doors, plain meeting stiles are required. Can also be fitted into the bottom rail of a metal door by the fabricator.

Min/Max Gap: 3mm to 14mm.

Finish: Satin clear (silver) or black anodised aluminium (15µm).

Fixing: Screw fix. Colour matched escutcheon plates and zinc plated, cross recess head S.T. screws supplied.

Seal: RP3126Si. Black silicon rubber (SE).

Sizes: 1500mm, 1220mm, 1070mm, 920mm, 820mm, 600mm to 305mm (min). Seals cut back to exact size.

Approvals

UL R37913.

Certifire CF 5710.

Acoustic AUS/NZ: NCC Spec. F5.5.
UK/EU: Approved Document E. Rated to BS EN ISO 717-1.

Fire AUS/NZ: NCC Spec. C3.4.
AS1530.4 & AS/NZS 1905.1. NZ BC Compliance Doc. C/AS1 6.19.2 & App. C6.1.1.

UK/EU: Approved Document B.
BS EN 1634-1.

FRL & FRR-/240/30.
Gasket flammability index 1 when tested to AS1530.2.

Smoke NCC Spec. C3.4. AS1530.7 & BS EN 1634-3. Meets smoke leakage rates specified in AS6905 & EN 13501-2 "Sa", "Sm".

Energy NCC Pt. 3.12.3.3 & J3.4.

Durability Tested to over 1,000,000 operating cycles without failure.

Insects/Vermin AS4674, 2.1.5(iv), 2.1.7.

Patented, Registered Design.

